

BMP C230: Straw Bale Barrier

<i>Purpose</i>	To decrease the velocity of sheet flows and intercept and detain small amounts of sediment from disturbed areas of limited extent, preventing sediment from leaving the site. See Figure 4.17 for details on straw bale barriers.
<i>Conditions of Use</i>	<p>Below disturbed areas subject to sheet and rill erosion.</p> <ul style="list-style-type: none">• Straw bales are among the most used and least effective BMPs. The best use of a straw bale is hand spread on the site.• Where the size of the drainage area is no greater than 1/4 acre per 100 feet of barrier length; the maximum slope length behind the barrier is 100 feet; and the maximum slope gradient behind the barrier is 2:1.• Where effectiveness is required for less than three months.• Under no circumstances should straw bale barriers be constructed in streams, channels, or ditches.• Straw bale barriers should not be used where rock or hard surfaces prevent the full and uniform anchoring of the barrier.
<i>Design and Installation Specifications</i>	<p>Bales shall be placed in a single row, lengthwise on the contour, with ends of adjacent bales tightly abutting one another.</p> <p>All bales shall be either wire-bound or string-tied. Straw bales shall be installed so that bindings are oriented around the sides rather than along the tops and bottoms of the bales in order to prevent deterioration of the bindings.</p> <ul style="list-style-type: none">• The barrier shall be entrenched and backfilled. A trench shall be excavated the width of a bale and the length of the proposed barrier to a minimum depth of 4 inches. The trench must be deep enough to remove all grass and other material that might allow underflow. After the bales are staked and chinked (filled by wedging), the excavated soil shall be backfilled against the barrier. Backfill soil shall conform to the ground level on the downhill side and shall be built up to 4 inches against the uphill side of the barrier.• Each bale shall be securely anchored by at least two stakes or re-bars driven through the bale. The first stake in each bale shall be driven toward the previously laid bale to force the bales together. Stakes or re-bars shall be driven deep enough into the ground to securely anchor the bales. Stakes should not extend above the bales but instead should be driven in flush with the top of the bale for safety reasons.• The gaps between the bales shall be chinked (filled by wedging) with straw to prevent water from escaping between the bales. Loose straw scattered over the area immediately uphill from a straw bale barrier tends to increase barrier efficiency. Wedging must be done carefully in order not to separate the bales.

***Maintenance
Standards***

- Straw bale barriers shall be inspected immediately after each runoff-producing rainfall and at least daily during prolonged rainfall.
- Close attention shall be paid to the repair of damaged bales, end runs, and undercutting beneath bales.
- Necessary repairs to barriers or replacement of bales shall be accomplished promptly.
- Sediment deposits should be removed after each runoff-producing rainfall. They must be removed when the level of deposition reaches approximately one-half the height of the barrier.
- Any sediment deposits remaining in place after the straw bale barrier is no longer required shall be dressed to conform to the existing grade, prepared and seeded.
- Straw bales used as a temporary straw bale barrier shall be removed after project completion and stabilization to prevent sprouting of unwanted vegetation.

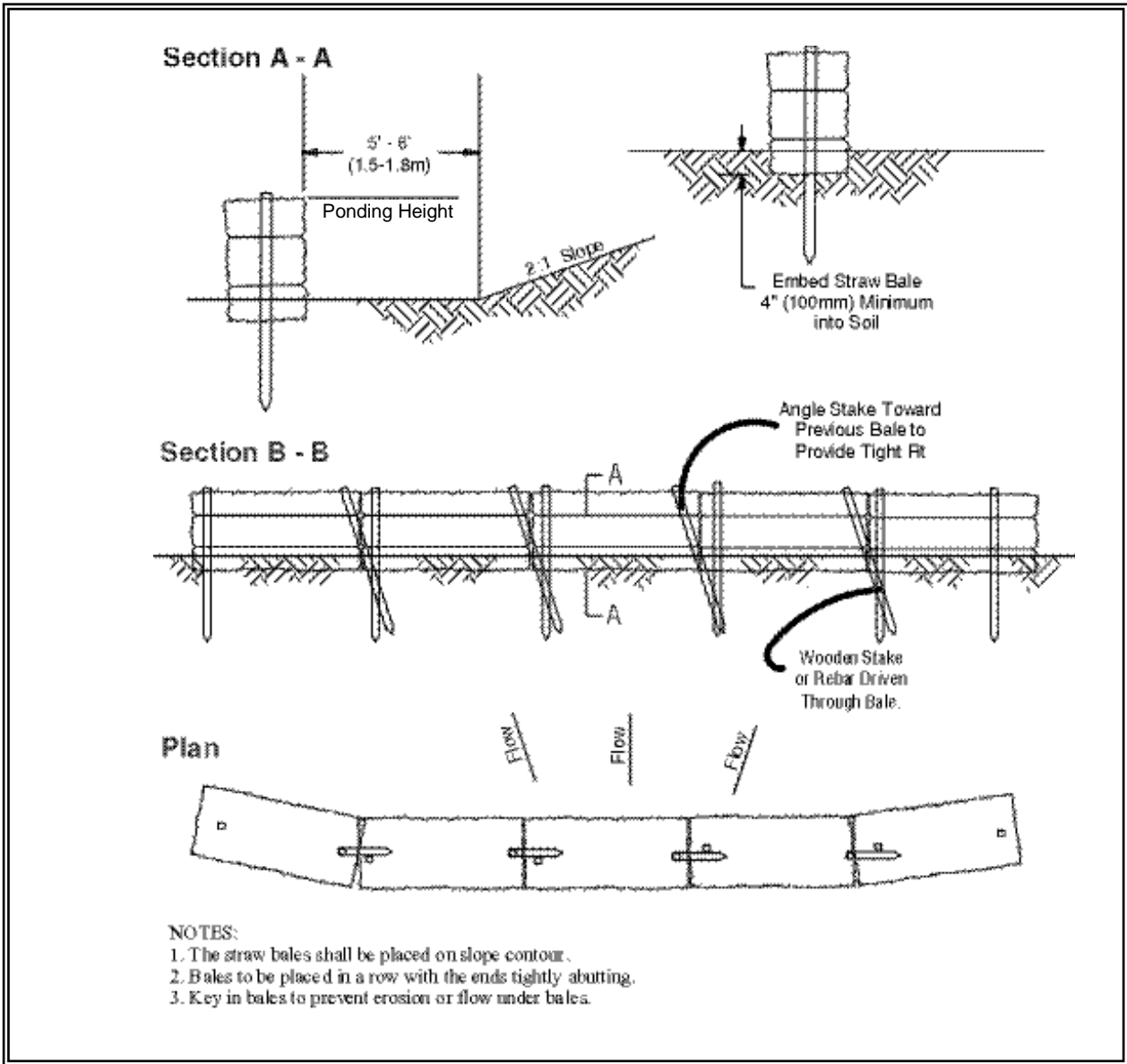

Figure 4.17 Straw Bale Barrier